

KV8080EZ Series Pivot Door Slides

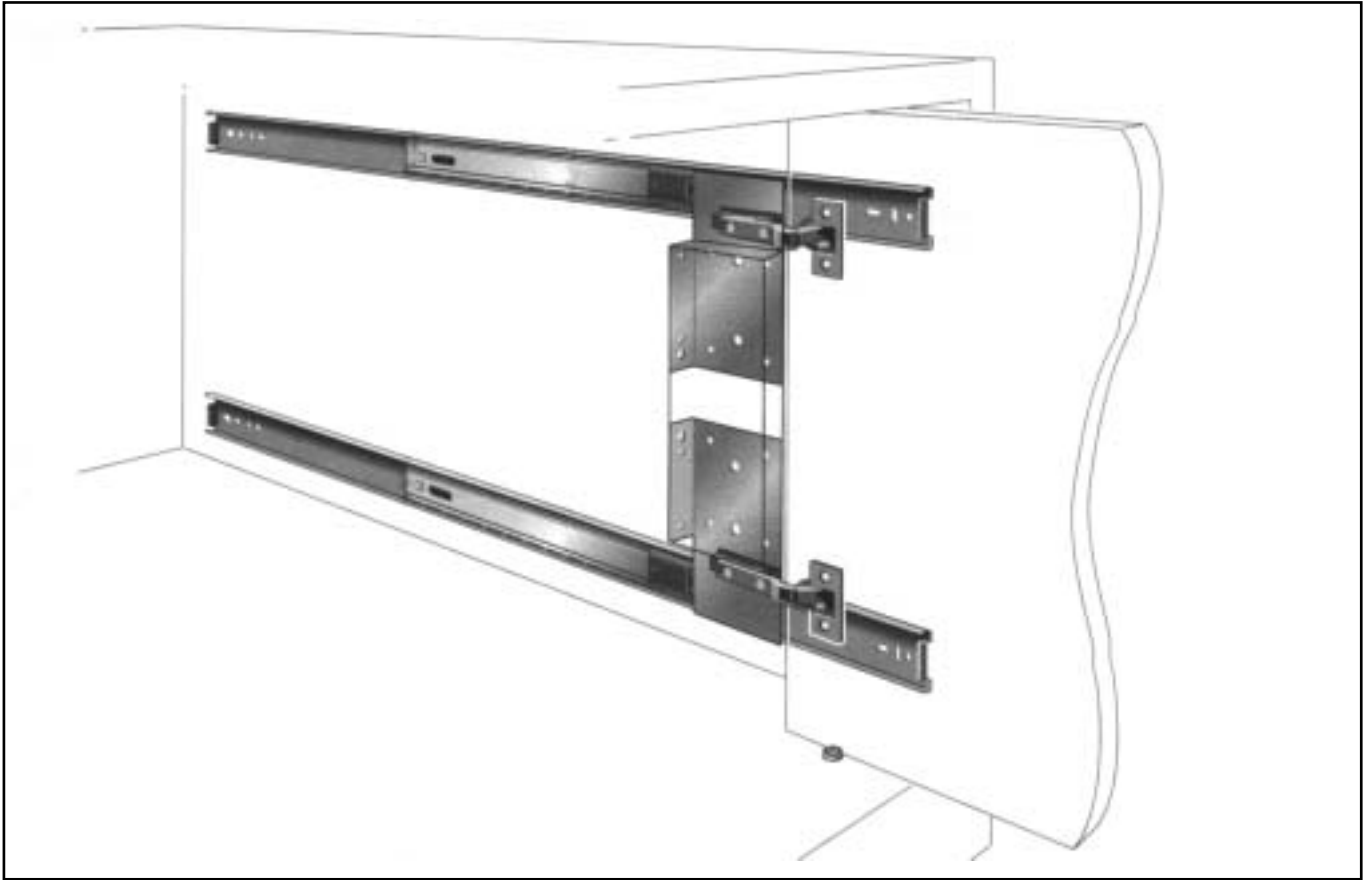

Specifications:

- 30 pound maximum per door
- Designed to mount to side of case for pocket door mode. For the flipper mode, door retracts inside of case
- Maximum door dimension of 24" x 42".
- Self-closing three-way adjustable geometric door hinge with single lever disconnect feature.
- Precision steel ball bearings.
- Large follower strip mounting plate for rigidity and installation ease.
- Bright electro-zinc plated and lacquered finish standard. Optional ebony black electro-zinc plated lacquer finish.

Limited Lifetime Warranty

Knape & Vogt Manufacturing Company guarantees its drawer slides and builder's hardware products against failure of defects for so long as the purchaser or end user owns them. This warranty is void if any damage to the product is due to misuse, neglect, accident, improper installation or any uses contrary to the instructions accompanying the product. This warranty covers the cost of the defective part and not the cost of removal, installation or other incidental charges. The foregoing are the purchaser's exclusive remedies. Knape & Vogt Manufacturing Company assumes no liability for special or consequential damages.

Replacement product may be obtained by returning the product, transportation charges prepaid, together with receipt of purchase or other documents acknowledging the sale of the product to the Knape & Vogt Manufacturing Company, Attention: Customer Service Department.

The warranty set forth above is in lieu of any other warranties, express or implied, including warranties of merchantability and fitness for use.



Installation Instructions for KV8080 Series Pivot Door Slides

READ INSTRUCTIONS FIRST!

These instructions show how to install the KV8080 Series Pivot Door Slide. Please note that improper installation may void the Knappe & Vogt Limited Lifetime Warranty. To install the slides correctly, follow the enclosed instructions, use only KV hardware and make no modifications. If you have questions or need additional information, please contact Knappe & Vogt customer service.

Typical Application

- Obtain appropriate hinge based on door thickness and operational requirements.
- Recommended maximum door dimension: 24" x 42". For larger doors, consult KV8081 pivot door instructions later in this document.

- Recommended maximum door weight: 30 lbs.
- Designed to mount vertically or horizontally.

Step 1. Install hinge cup in cabinet door

Determine location of hinge hole centers. Bore two holes at back inside edge of door following chart recommendations (chart 2) for bore diameter and edgebore distance based on hinge being used. Always bore on a test block first to verify hinge cup locations. Install hinges in door.

Step 2. Follower strip fabrication and attachment

- Cut a follower strip 2 3/4" to 3" wide, x 1/2" minimum thickness. Size the length 2" less than hinge cup centerline distance (dimension A as shown on figure 1 & 2).
- Attach hinged door assembly to hinge bases on slides by snapping them in place.
- Center follower strip across mounting plates and fasten screws. For maximum rigidity, install six screws in each mounting plate.

Step 3. Install slide and follower strip assembly to inside of case.

- Detach door and hinges from the slide and follower strip assembly, by pulling upward on the release lever located at the end of the hinge.
- Centralize slide and follower strip assembly into case, keeping each slide center line to edge of case distance equal to dimension B (figure 1 & 2) plus suggested gap dimension of 1/8" minus 5/8" allowance for hinge offset.
- Slides must be parallel to case edge.
- Slides must also be set back from the front of the case a distance equal to the door thickness plus 1/4", as shown (figure 4). Measure this dimension from the edge of the slide roller. Mount slides first through slotted holes to allow for adjustment, if needed. When final adjustments are complete, install additional screws in fixed holes.

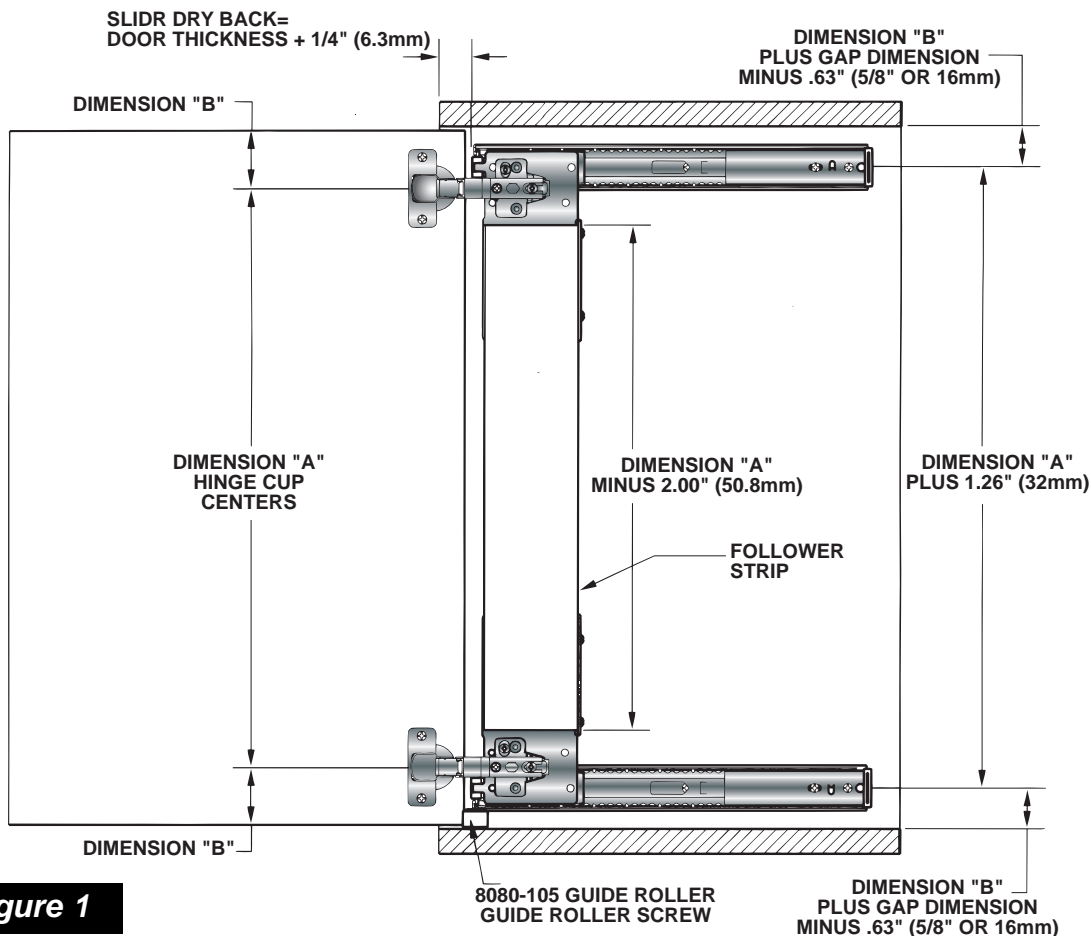

figure 1

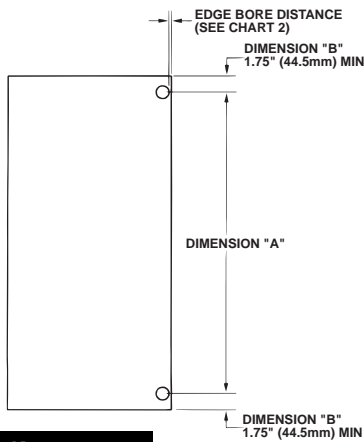

figure 2

DOOR PREPARATION

Step 4 Door guide roller installation.

- Proper operation requires precise roller location - drill pilot hole for screw located from case edges as shown (**figure 4**).
- Secure guide roller using flat-head wood screw supplied. Tighten screw enough to still allow roller to freely turn..

IMPORTANT: Roller assembly should not bind on door. Always install the 8080 pivot door slide using bottom guide roller provided with slide. If roller is missing or lost, contact KV customer service for replacement - DO NOT substitute other rollers. This roller, when properly installed, assures the smoothness of operation. When improperly installed, the slides could be damaged. Locate the rollers as shown.

Step 5 Hinged door attachment and adjustment.

- Clip door hinges to hinge base by aligning hooks on the underside of the hinge with the front tongue on the hinge base and then pressing on the rear portion of the hinge until spring lever engages.

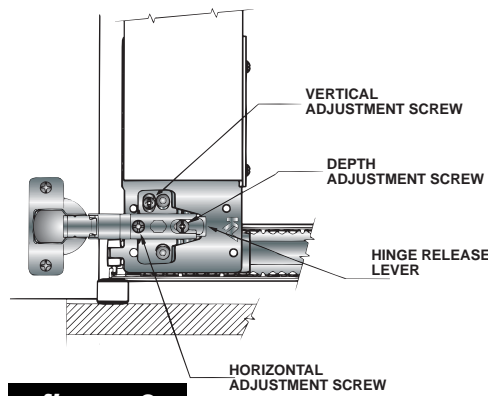

figure 3

HINGE ADJUSTMENT

- Carefully close door and observe for any needed adjustment, then open door to adjust hinge as required.
- Turn hinge screws to adjust door in all three directions.

Horizontal adjustment screw - adjusts door side gap clearance. **Do not over adjust - this screw MUST NOT be tight.**

Depth adjustment screw - adjusts door face in and out (flush with case edge). Screw must be tight.

Vertical adjustment screw - adjusts door up and down (top and bottom gap clearance). **Screw must be tight.**

Door removal can be accomplished by pulling the release lever located at the end of the hinge upward.

Installation Instructions for KV8081 Pivot Door Slide

Step 2 Hinge base attachment

- Fasten appropriate hinge bases* to mounting plates by means of two #8-32 x 1/4" long flat-head self-tapping screws (provid-

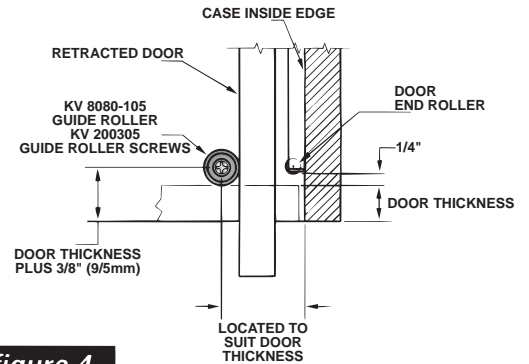

figure 4

DOOR GUIDE ROLLER INSTALLATION

ed). See **figure 5** for hole location. *Requires 0mm thick wing type hinge base. The self-tapping mounting screws provided may not be compatible with all manufacturers' hinge bases. **If a substitute screw is used, check for proper thread engagement and clearance above the ball retainer.** An optional screw (KV#200283) is available that is 5/16" in length.

Typical Hinge Specification

For doors 5/8" to 3/4" thick, hinges are available from Mepla, Blum, Grass, Salice and Hettich.

These manufactures are familiar with the KV8081 slide and can assist you in selecting the appropriate hinge for your application. For typical applications, KV recommends the following specification.

Hinge: 95° half overlay self-closing thick door hinge

Hinge Base: 0mm thick, 32mm wing type hinge base with 37mm setback.

chart 1

Size	L	Approx. Door Conceal**	Approx. Cabinet Depth***
*12"	12-1/8"	9"	12-3/8"
13"	13-1/8"	10"	13-3/8"
14"	14-1/8"	11"	14-3/8"
15"	15-1/8"	12"	15-3/8"
*16"	16-1/8"	13"	16-3/8"
17"	17-1/8"	14"	17-3/8"
*18"	18-1/8"	15"	18-3/8"
19"	19-1/8"	16"	19-3/8"
20"	20-1/8"	17"	20-3/8"
21"	21-1/8"	18"	21-3/8"
*22"	22-1/8"	19"	22-3/8"
23"	23-1/8"	20"	23-3/8"
*24"	24-1/8"	21"	24-3/8"

* Stock Size

** Door fully retracted

*** Add thickness of door to determine minimum

figure 10

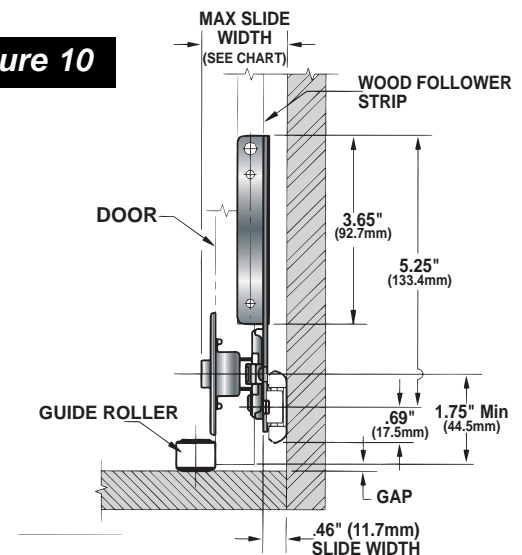

figure 9

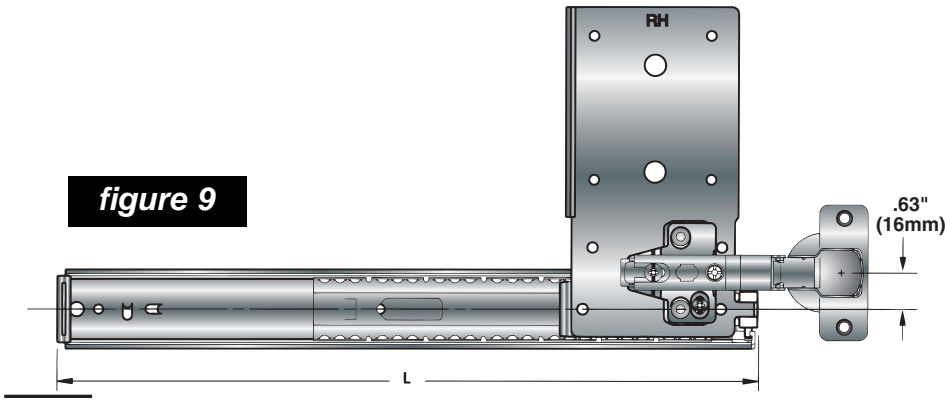

figure 11

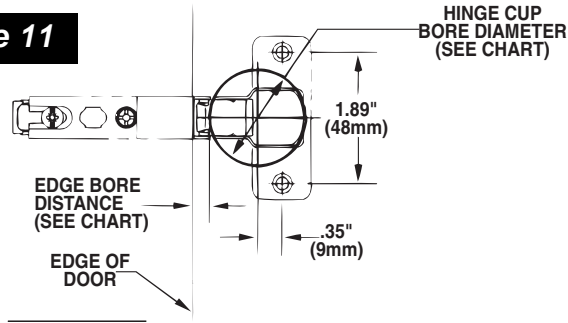

figure 12

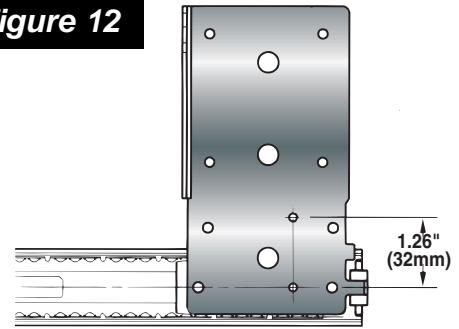

chart 2

Hinge Options	Hinge Description	Door Thickness	Edge Bore Distance	Maximum Slide Width Hinge Bore Dia.	Including Hinge For Partition Installations	Partial Overlay
8080	Standard Hinge	3/4" (19mm)	1/4" (6mm)	1-3/8" (35mm)	1-23/32" (43.7mm)	N/A
8080 FS	Standard Hinge w/ free swing knuckle	3/4" (19mm)	1/4" (6mm)	1-3/8" (35mm)	1-23/32" (43.7mm)	N/A
8080L	Overlay Door	3/4" (19mm)	7/16" (11mm)	1-37/64" (40mm)	1-23/32" (43.7mm)	13/32" (10.3mm)
8085	Thick Door	1" (25.4mm)	5/16" (8mm)	1-37/64" (40mm)	2-3/32" (53.2mm)	N/A
8086	Extra Thick Door	1-1/4" (32mm)	1/2" (12.7mm)	1-37/64" (40mm)	2-13/32" (61mm)	N/A

figure 10

MOUNTING HOLE DIMENSIONS

